

Product Features

- SFN time and frequency synchronization
- Serial ASI selectable inputs and outputs
- Bit rates adjusted with transmission mode
- Rear panel monitoring ports for TS and sync output
- Supports hierarchical mode
- Compliant with DVB standards: EN 300 744 and TS 101 191



Description and Application

Overview

For the operation of digital terrestrial TV networks, DVB-T and/or DVB-H (software selectable), where several transmitters broadcast the same programs on the same RF channel frequencies (Single Frequency Networks), the transmitters require precise frequency and time synchronization. The frequency (10 MHz) and time (1 pps) reference signals can be easily obtained from a GPS receiver at each transmission site.

The UBS DVS 4010 SFN Adapter fulfils the task of inserting "synchronization marks" in a DVB transport stream (MIP insertion) in full accordance with DVB-T/H standards.

The basic functions performed by the DVS 4010 SFN adapter are:

- Inserts a megaframe initialization packet (MIP) into an MPEG transport stream
- Adjusts the bitrate of the transport stream to be synchronous with an external reference, and in accordance with the chosen COFDM transmission mode
- Provides signaling/mode data for the control of individual transmitter modulators

MIP Insertion

MIP insertion occurs once per megaframe, with a time interval dependent on the selected guard interval.

The MIP indicates when the first packet in a mega-frame (Synchronization Time Stamp, STS) begins transmitting.

The time reference is an external 1 pulse per second signal, easily obtained from a GPS receiver.

Bitrate Adaptation

The DVS 4010 is provided with two serial (ASI) inputs that accept an MPEG transport stream according to DVB recommendations (188 or 204 byte packets). The output may be configured as either 188 or 204 byte packets, however, for 204 byte packets, there is no RS encoding and the last 16 bytes are dummy bytes.

Note: the maximum bitrate has to include the inserted MIP, which means the input net bitrate must be slightly lower than the maximum.

The SFN Adapter removes null packets from the input signal and inserts MIP packets. New null packets are then added to produce a precise output bitrate, which is required for the selected transmission mode (dependent on code rate, constellation and guard band). The maximum allowable net bitrate is governed by the selected transmission mode, according to the DVB-T standard EN 300 744. As the transport rate is modified, the SFN adaptor performs PCR re-stamping.

Control

The DVS 4010 is controlled locally, with a display and push buttons, or remotely, using the serial RS232 and/or RS485 ports.

All mandatory system parameters, as defined in the ETSI standard TS 101 191, may be set from the remote interface.

An Ethernet (10/100 Base-T) interface is also available for remote control and remote software upgrade.

Alarms

One alarm circuit is provided and may be "armed" for a number of conditions important for correct operation. The alarm output is via floating contacts on the rear panel and the alarm information is also available via remote control.

DVB-T/H SFN Adapter

Model: DVS 4010

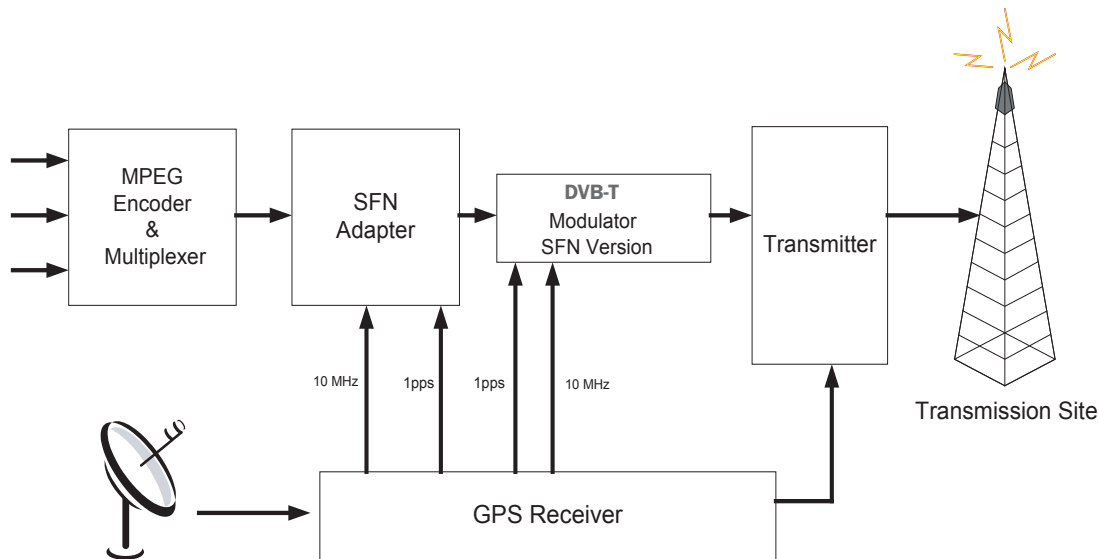

Optional Features

Web Interface

The web interface allows remote control of the DVS 4010 via Ethernet (TCP/IP). The system is based on a Web server mounted inside the DVS 4010. The Web pages stored on the Web server are designed as a complete graphical user interface (GUI) for testing the status and setting the parameters of the SFN adapter.

The Web Interface concept is popular because remote control of this system only requires a standard PC with a network interface card (NIC) and a Web browser (Microsoft Explorer 6.0).

SNMP

This feature allows remote control of the DVS 4010 in accordance with SNMP protocol (Get, Set and SNMP traps). This remote control option is intended for system solutions where it is desired to integrate the control of a range of SNMP compliant equipment in a common management system.

Modes of Operation

DVB-H - This mode allows the modulator to generate a DVB-H COFDM signal, in accordance with the ETSI DVB-H standards.

DVB-T - This mode allows the modulator to generate a DVB-T COFDM signal, in accordance with the ETSI DVB-T standards.



DVB-T/H SFN Adapter

Model: DVS 4010

Product Specifications (specifications are subject to change without notice)

Transport Stream Processing

Input monitoring	<ul style="list-style-type: none"> • Transport stream presence • Clock recovered (serial input) • Input Data overflow • Sync 188 byte presence • Sync 204 byte presence (+16 dummy bytes or RS coded packet)
Supported Modes	IFFT: 2K, 4K, 8K
Guard Intervals	1/4, 1/8, 1/16, 1/32
Code Rates	1/2, 2/3, 3/4, 5/6, 7/8
Constellations	QPSK, 16-QAM, 64-QAM
Network Mode	SFN and MFN
Bandwidth	8 MHz, 7 MHz, 6 MHz, 5 MHz
Hierarchical Mode	Alpha - 1, 2 and 4 for 16-QAM and 64-QAM
Max Delay (data)	0 - 1.0 sec, resolution 100 ns
Signal Substitution	Output transport stream is replaced with null packets and MIP in case of input data loss

Signal Inputs

MPEG-2 Transport Stream	2 ASI inputs: BNC (F), 75 ohm (software selectable)
Clock Reference - 10 MHz	Connector: BNC (F) Frequency: 10 MHz \pm 2 ppm Level: 100 mV - 3 Vpp Impedance: 50 ohm, AC coupled
Time Reference - 1 PPS	Connector: BNC (F) Frequency: 1 PPS Amplitude Level: TTL Trigger: Positive transition Impedance: 50 ohm

Transport Stream Output

Connectors	2 ASI outputs: BNC (F), 75 ohm
-------------------	--------------------------------

Monitoring Output

Sync Output	Connector: BNC (F), 50 ohm Level: TTL (High coincides with MIP or SIP packet)
--------------------	--

Control Interfaces

Front Panel	LCD display and cursor/ execute keys
RS232	Connector: 9-pin SUB-D Male Protocol: Approximated SCPI
RS485 (electrical)	Connector: 9-pin SUB-D Female (on request)
WEB Interface	Connector: RJ45
SNMP Control Interface	Ethernet 10/100 Base-T
Telnet	

Alarms

Connector	9-pin SUB-D Female, with relay contacts
Alarm Sources	Loss of sync Loss of data Loss of serial clock regeneration Loss of reference: 10 MHz, 1 pps

Power Supply

Voltage	90 - 250 VAC
Frequency	47 - 63 Hz
Power Consumption	max. 50 VA

Mechanical

Size	1 U of 19" wide cabinet
Dimensions (W x H x D)	432mm x 44mm x 432mm (17.5" x 1.75" x 17.0")
Weight	6 kg (13 lbs.)

Environmental

Operating Temperature	5°C to 45°C (41°F to 113°F)
Storage Temperature	-30°C to 70°C (-22°F to 158°F)
Relative Humidity (operating/storage)	max. 90%
Cooling	Temperature controlled fan to assist natural convection

Electromagnetic Compatibility

Electromagnetic Interference	Complies with the CENELEC requirements for radiation and immunity EN 55022 and EN 55024
-------------------------------------	---

Safety	In accordance with IEC 60950
---------------	------------------------------

Compliance	Compliant with DVB standards: EN 300 744 and TS 101 191
-------------------	---