

## DTMB SFN Adapter

Model: DTMB 4010

### Product Features

- SFN time and frequency synchronization
- Serial ASI selectable inputs and outputs
- Bit rates adjusted with transmission mode
- Rear panel monitoring ports for TS and sync output
- MIP or SIP insertion (software selectable)



### Description and Application

#### Overview

For the operation of DTMB digital terrestrial TV networks, where several transmitters broadcast the same programs on the same RF channel frequencies (Single Frequency Networks), the transmitters require precise frequency and time synchronization. The frequency (10 MHz) and time (1 pps) reference signals can be easily obtained from a GPS receiver at each transmission site.

The UBS DTMB 4010 SFN Adapter fulfils the task of inserting "synchronization marks" in a DTMB transport stream (MIP or SIP insertion) in full accordance with DTMB standards (GB20600-2006, GY/T 229.1-2008).

The basic functions performed by the DTMB 4010 SFN adapter are:

- Inserts a megaframe initialization packet (MIP) or second frame initialization packet (SIP) into an MPEG transport stream
- Adjusts the bitrate of the transport stream to be synchronous with an external reference, and in accordance with the chosen COFDM transmission mode
- Provides signaling/mode data for the control of individual transmitter modulators

#### MIP Insertion

MIP insertion occurs once per megaframe (once per second) and indicates when the first packet in a mega-frame (Synchronization Time Stamp, STS) begins transmitting.

The time reference is an external 1 pulse per second signal, easily obtained from a GPS receiver.

#### SIP Insertion

SIP insertion occurs once per second and is synchronized with the 1PPS signal from a GPS receiver. The SIP contains the transmission parameters for the modulator and the SFN maximum delay.

#### Bitrate Adaptation

The DTMB 4010 is provided with two serial (ASI) inputs that accept an MPEG transport stream according to DTMB recommendations (188 byte packets). The output is also 188 byte packets.

Note: the maximum bitrate has to include the inserted MIP or SIP (as selected), which means the input net bitrate must be slightly lower than the maximum.

The SFN Adapter removes null packets from the input signal and inserts MIP or SIP packets (as selected). New null packets are then added to produce a precise output bitrate, which is required for the selected transmission mode (dependent on code rate, constellation and guard band). The maximum allowable net bitrate is governed by the selected transmission mode, according to the DTMB standards. As the transport rate is modified, the SFN adaptor performs PCR re-stamping.

#### Control

The DTMB 4010 is controlled locally, with a display and push buttons, or remotely, using the serial RS232 and/or RS485 ports.

All mandatory system parameters, as defined in the DTMB standards, may be set from the remote interface.

An Ethernet (10/100 Base-T) interface is also available for remote control and remote software upgrade.

#### Alarms

One alarm circuit is provided and may be "armed" for a number of conditions important for correct operation. The alarm output is via floating contacts on the rear panel and the alarm information is also available via remote control.

## DTMB SFN Adapter

Model: DTMB 4010

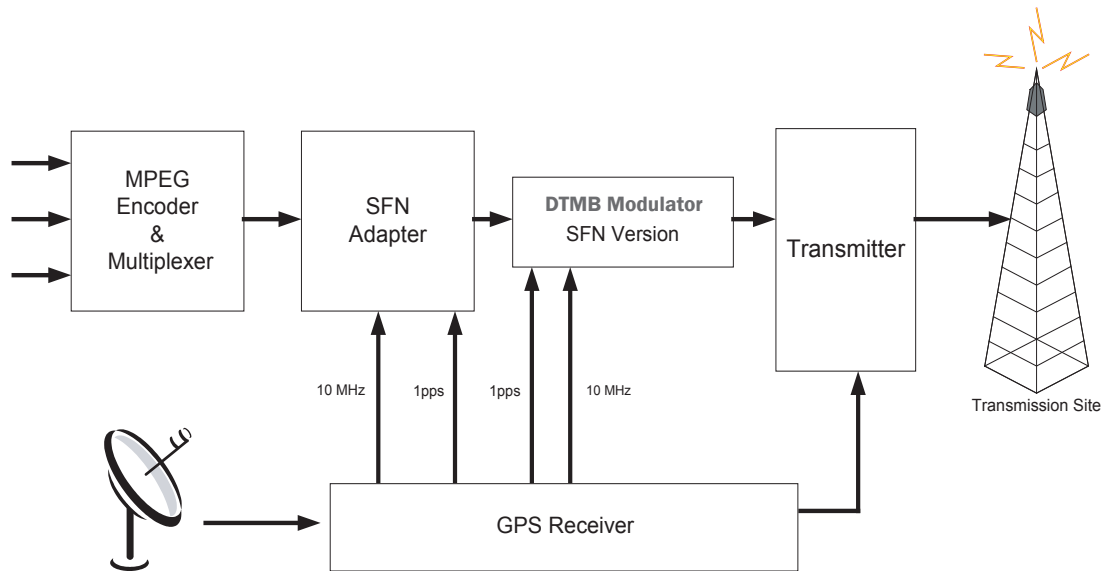

## Optional Features

### Web Interface

The web interface allows remote control of the DTMB 4010 via Ethernet (TCP/IP). The system is based on a Web server mounted inside the DTMB 4010. The Web pages stored on the Web server are designed as a complete graphical user interface (GUI) for testing the status and setting the parameters of the SFN adapter.

The Web Interface concept is popular because remote control of this system only requires a standard PC with a network interface card (NIC) and a Web browser (Microsoft Explorer 6.0).

### SNMP

This feature allows remote control of the DTMB 4010 in accordance with SNMP protocol (Get, Set and SNMP traps). This remote control option is intended for system solutions where it is desired to integrate the control of a range of SNMP compliant equipment in a common management system.

**DTMB SFN Adapter**

Model: DTMB 4010

**Product Specifications** (specifications are subject to change without notice)**Transport Stream Processing**

<b>Input monitoring</b>	<ul style="list-style-type: none"> <li>• Transport stream presence</li> <li>• Clock recovered (serial input)</li> <li>• Input Data overflow</li> <li>• Sync 188 byte presence</li> </ul>
<b>Supported Modes</b>	IFFT: 3780, Single Carrier
<b>Guard Intervals</b>	945, 595, 420 symbols
<b>Code Rates</b>	0.4, 0.6, 0.8
<b>Constellations</b>	QPSK, 4-QAM-NR, 16-QAM, 32-QAM, 64-QAM
<b>Frame Duration</b>	500 us, 571.43 us, 666.67 us
<b>Sub-Carrier Spacing</b>	1.5 kHz, 1.75 kHz, 2 kHz
<b>Time Interleaver</b>	240, 720 symbols
<b>Network Mode</b>	SFN and MFN
<b>Channel Bandwidth</b>	8 MHz
<b>Max Delay (data)</b>	0 - 1.0 sec, resolution 100 ns
<b>Signal Substitution</b>	Output transport stream is replaced with null packets and MIP (or SIP), in case of input data loss

**Signal Inputs**

<b>MPEG-2 Transport Stream</b>	2 ASI inputs: BNC (F), 75 ohm (software selectable)
<b>Clock Reference (10 MHz Reference from GPS receiver)</b>	Connector: BNC (F) Frequency: 10 MHz $\pm$ 2 ppm Amplitude: 100 mV - 3 Vpp Impedance: 50 ohm, AC coupled
<b>Time Reference (1 PPS signal from GPS receiver)</b>	Connector: BNC (F) Frequency: 1 PPS Amplitude: TTL Trigger: Positive transition Impedance: 50 ohm

**Transport Stream Output**

<b>Connectors</b>	2 ASI outputs: BNC (F), 75 ohm
-------------------	--------------------------------

**Monitoring Output**

<b>Sync Output</b>	Connector: BNC (F), 50 ohm Level: TTL (High coincides with MIP or SIP packet)
--------------------	--

**Control Interfaces**

<b>Front Panel RS232</b>	LCD display and cursor/ execute keys Connector: 9-pin SUB-D Male Protocol: Approximated SCPI
<b>RS485 (electrical)</b>	Connector: 9-pin SUB-D Female, on request
<b>WEB Interface SNMP Control Interface Telnet</b>	Ethernet 10/100 Base-T Connector: RJ45

**Alarms**

<b>Connector</b>	9-pin SUB-D Female, with relay contacts
<b>Alarm Sources</b>	Loss of sync Loss of data Loss of serial clock regeneration Loss of reference: 10 MHz, 1 pps

**Power Supply**

<b>Voltage</b>	90 - 250 VAC
<b>Frequency</b>	47 - 63 Hz
<b>Power Consumption</b>	max. 50 VA

**Mechanical**

<b>Size</b>	1 U of 19" wide cabinet
<b>Dimensions (W x H x D)</b>	432mm x 44mm x 432mm (17.5" x 1.75" x 17.0")
<b>Weight</b>	6 kg (13 lbs.)

**Environmental**

<b>Operating Temperature</b>	5°C to 45°C (41°F to 113°F)
<b>Storage Temperature</b>	-30°C to 70°C (-22°F to 158°F)
<b>Relative Humidity (operating/storage)</b>	max. 90%
<b>Cooling</b>	Temperature controlled fan to assist natural convection

**Electromagnetic Compatibility**

<b>Electromagnetic Interference</b>	Complies with the CENELEC requirements for radiation and immunity EN 55022 and EN 55024
-------------------------------------	---

<b>Safety</b>	In accordance with IEC 60950
---------------	------------------------------

<b>Compliance</b>	Compliant with DVB standards: EN 300 744 and TS 101 191
-------------------	---